

Adaptable Wall

Product Summary



Optima

Adaptable Wall

The Optima Adaptable Wall is a modular, dry jointed solid wall system which maintains acoustic integrity throughout the project. Fully demountable and reconfigurable, this dynamic system is perfect for projects where the environmental aspects of the materials used are a key design element.

Ready to be flexible

Optima's AW system is designed to complement a standard installation of Optima Revolution 100 glazed partitions. This fully modular system utilises the same aluminium track but with a variety of solid panels in place of the glass.

AW represents a real alternative to traditional drywall or plasterboard installations in commercial environments.

The system is ideal for internal walls next to glazed partitions, in areas surrounding traditional enclosed spaces, but can be used on most walls in an office.

AW boasts many advantages over standard partition walls including speed, flexibility and cleanliness during construction, as well as adaptability and sustainability in the long term.

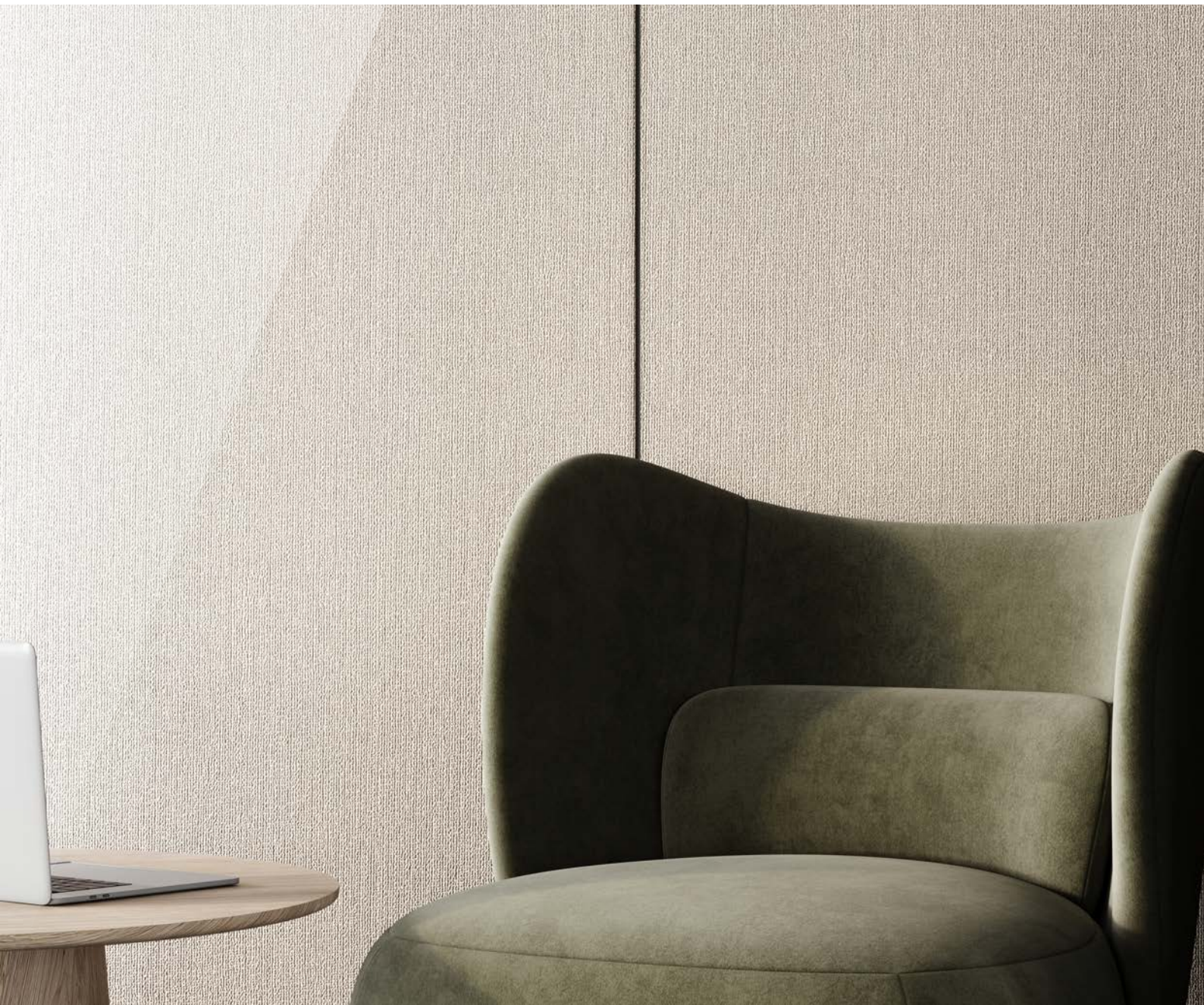



Quick and easy installation

Efficiency

The modular system's simple one stage installation process can accelerate building programmes by using our trained glazing fitters to complement existing trades on site.

Putting up and taking down the Adaptable Walls is easy if you know how. The Optima patented clamping system aids the speed of assembly, with the modularity of the design key to this. Our dedicated team of Project Managers and Site Managers understand how to consistently deliver exceptional customer service and the highest quality installations, on-time and within budget.

Cleaner on site

The use of modular pre-fabricated sections minimises cutting on site and eliminates water and plaster mess leading to a cleaner site. AW requires no drying time and is installed later in the project than traditional alternatives, it's installed faster and reduces the chance of damage and further delay.

Reduced lead times

All AW components are standardised, and we hold fundamental configuration components in stock, making them available 'off the shelf'. Stock levels will be maintained to reduce any lead times, dependent on requirements.

Sustainability



AW is compatible with Sustainability Assessment schemes such as BREEAM, SKA, LEED and WELL, focussing on environmental impact, material responsible sourcing and waste reduction.



Recycled content

Both the track and panels are manufactured from sustainable sources, contain recycled content and can be reused or recycled.

Reusable

Unlike traditional walls, AW is fully relocatable. If the office layout needs to change then the system can simply be dismantled and reassembled in an alternative location saving money and reducing waste.

Reduced waste

As the system is based on modular components of set dimensions, waste from offcuts at installation are minimal.



Finish options

The panels can be finished in a wide variety of materials such as laminate, fabric, acoustic treatment, glass-boards or even living walls. The options are endless and both aesthetics and functionality can be enhanced by applying different finishes to adjacent panels or on both sides of the same panel.

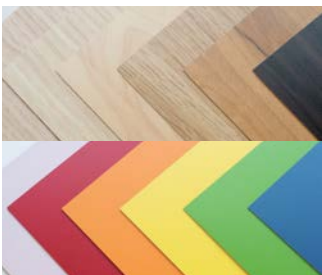

Laminate panels (MFC)
Solid walls can be covered in a range of laminate finishes. All standard colours and wood effects are available.



Magnetic writable glass
Turn your wall into an inspirational canvas. The magnetic glass technology redefines walls into functional dry-erase and "tack" friendly collaborative surfaces.

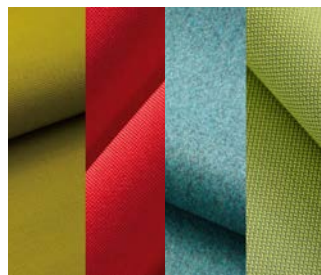

Pinnable fabric
Textiles used in these fabric panels come in a wide range of designs and colours.



Industrial finish options
Complement an industrial style interior with a range of materials featuring a raw or untreated finish, allowing natural components to form part of the interior.

Technical drawings

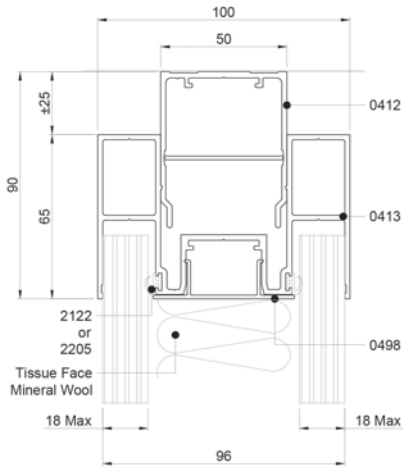

25mm inner deflection head track double solid panel

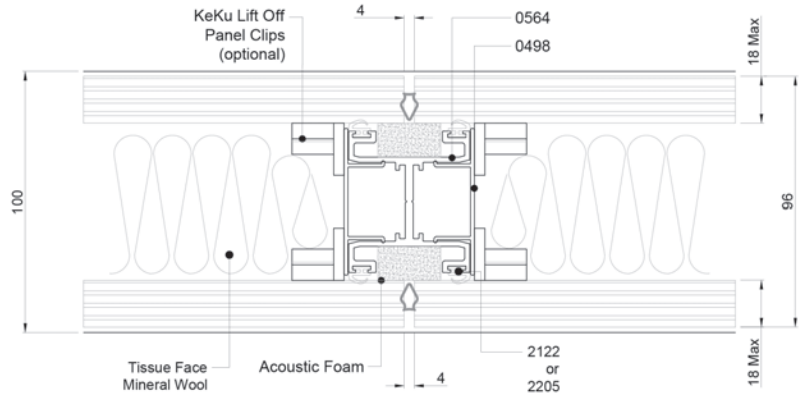

hidden mullion double solid panel

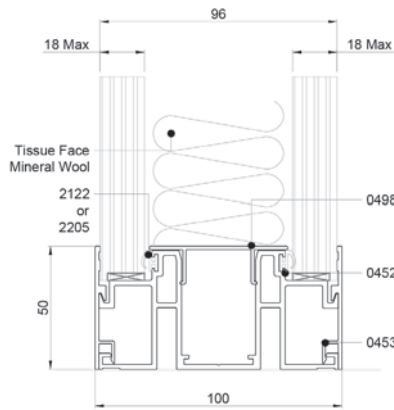

50mm base track double solid panel

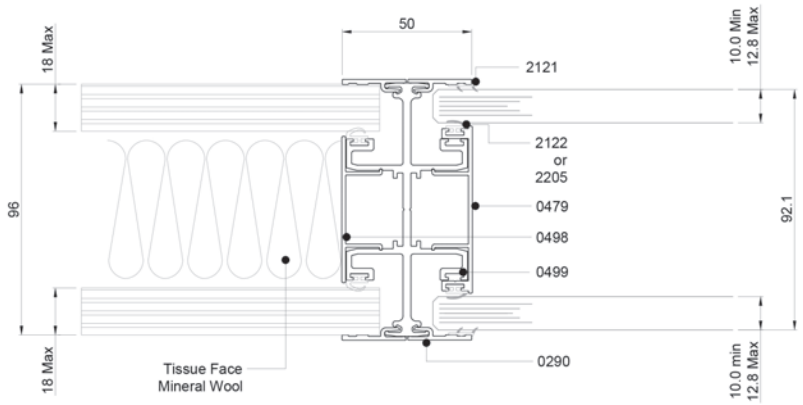

mullion detail double solid panel/double glazed

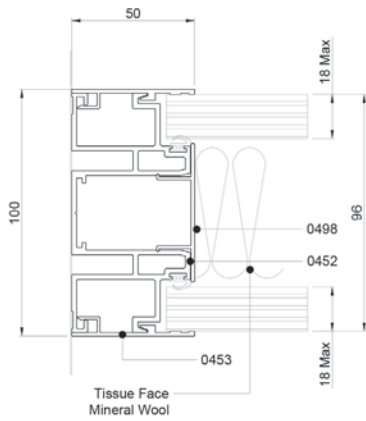

50mm wall abutment double solid panel

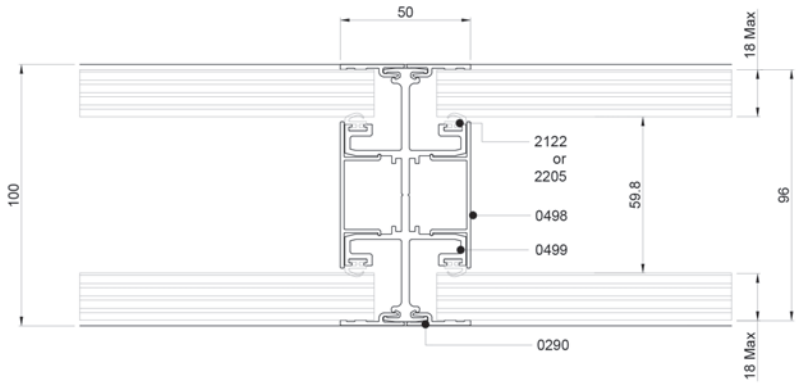

50mm mullion double solid panel

Flexible technology

Technology panels are designed to accommodate a range of technology options. The demountable panel system facilitates easy cable access for services including power, data, video, audio, etc.

Modular panels have integral strength capable of supporting large items including screens. New technologies can easily be retrofitted as they are adopted without mess or waste.

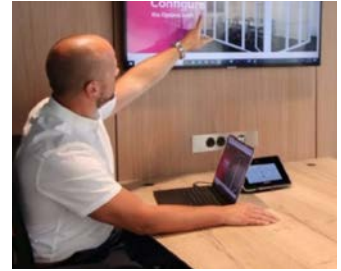

Acoustic performance

The system is ideal for internal walls next to glazed partitions - in areas surrounding traditional enclosed spaces. The Adaptable Wall will provide both acoustic privacy and comfort. The exact levels will depend on the specification of the panel and the finish selected.

Sound Insulation to BS EN ISO 10140 - 2 and ISO 717-1:

dB (Rw)*	Face 1	Face 2	Performance certificate
46	Fabric wrapped MDF	Fabric wrapped MDF	500-OPL-CRT-PFC-00100
48	Fabric wrapped MDF	Laminate faced MDF	500-OPL-CRT-PFC-00101
48	Laminate faced MDF	Laminate faced MDF	500-OPL-CRT-PFC-00102
48	Fabric wrapped pinnable board	Laminate faced MDF	500-OPL-CRT-PFC-00103
48	Fabric wrapped pinnable board	Fabric wrapped MDF	500-OPL-CRT-PFC-00104
48	Fabric wrapped pinnable board	Pinnable board	500-OPL-CRT-PFC-00105
50	Magnetic writable glass	Fabric wrapped MDF	500-OPL-CRT-PFC-00106
51	Magnetic writable glass	Laminate faced MDF	500-OPL-CRT-PFC-00107
51	Magnetic writable glass	Fabric wrapped pinnable board	500-OPL-CRT-PFC-00108

* Value relates to Face 1 and Face 2 combined